



City of Pewee Valley, Kentucky
P. O. Box 769 • 312 Mt. Mercy Drive • Pewee Valley KY 40056
502-241-8343 Office • 502-241-8348 Fax

PERMANENT SIGN PERMIT APPLICATION

Date: December 11, 2018

Donna Russell, Pewee Valley Historian (502) 741-1007
Contact Name Phone

Pewee Valley Historical Society
Business/Organization Name

312 Mt. Mercy Drive (P.O. Box 769) Pewee Valley, KY 40056
Mailing Address (address/city/state/zip)

See attached
Location of Sign (address & placement on property)

Historical Markers for Walking/Driving Tour Program
Type of Sign (if a temporary event sign, use the Special Event Permit Application)

Application must include drawings of proposed sign containing specifications indicating color(s), height, perimeter dimensions, means of support, method of illumination (if any), and any other significant aspect of proposed sign and any other information requested by the Mayor and City Council to be considered for approval.

Applicant is responsible for contacting the Oldham County Planning & Development Office to ensure compliance with Oldham County's ordinance regarding signs.

Applications and \$20 Review Fee for Sign Permits must be received by the City Clerk no later than 21 days prior to a regular scheduled City Council Meeting to be included on the Meeting Agenda for consideration. City Council Meetings are held the first Monday of each month.

Applicant Signature Date

Potential Locations for Historical Signage

Central Avenue Historic District

- [James Foley House](#), 212 Mt. Mercy Drive, ca. 1875
- [Pewee Valley State Bank](#), 218 Mt. Mercy Drive, 1910 (now the Pewee Valley Woman's Club)
- [Woodside](#), 110 Central Avenue, ca. 1857
- [Bemersyde](#), 114 Central Avenue, ca. 1857
- [Sunnyside/Edgewood](#), 114 Edgewood Way, ca. 1858
- [Twigmore](#), 121 Peach Lane, 1923
- [Peace Farm](#), 100 Peace Lane, ca. 1880
- [Genevieve and Alfred Chesheir House](#), 120 Peace Lane, 1923
- [The Beeches](#), 125 Central Avenue, 1902
- [The Gables](#), 121 Central Avenue, 1895
- [W.N. Jurey's General Store](#), 200 Mt. Mercy Drive, 1912
- [Woodruff-Foley Brothers General Store](#), 220 Mt. Mercy Drive, ca. 1880

Ashwood Avenue Historic District

- [Washburne-Waterfill House](#), 100 Ash Avenue, 1902
- [Washburne-Swan House](#), 106 Ash Avenue, 1905
- [William Logsdan House](#), 110 Ash Avenue, 1936
- [Carrie D. Coleman House](#), 112 Ash Avenue, ca. 1911
- [Truman-Nock House](#), 116 Ash Avenue, ca. 1890
- [Sherman and Corey Jurey Weatherly House](#), 111 Ash Avenue, 1905
- [115 Ash Avenue](#), ca. 1905
- [Mary Cleland House](#), 117 Ash Avenue, ca. 1915
- [Charles Hoffman House](#), 121 Ash Avenue, ca. 1916

Wooldridge Avenue-LaGrange Road Area (not all are on the register)

- [Muir-Fetter House](#), 400 LaGrange Road, 1905 (*don't know what to do about this – current house is 1905, earlier house on same foundation dates to ca. 1856 and there remain problems with putting information about the house on the website – I have gotten around the problem by putting information about the owners out under the People section*)
- [Truman-Miller-Richard House](#), 500 LaGrange Road, ca. 1870
- [Wooldridge-Briggs House](#), 305 Wooldridge Avenue, ca. 1905
- [Wooldridge-Rose House](#), 315 Wooldridge Avenue, ca. 1905* NR
- [The Locust](#), 6917 LaGrange Road, ca. 1800* NR
- [Haywood House](#), 6901 LaGrange Road, ca. 1910
- [Rush-Gheens House](#), 13608 LaGrange Road, ca. 1871
- [Gheens-Becker House](#), LaGrange Road, ca. 1880

Other National Register Properties

- [William Alexander Smith House](#), 108 Mt. Mercy Drive, 1860
- [St. James Episcopal Church](#), 401 LaGrange Road, 1869
- [St. Aloysius Church](#), 201 Mt. Mercy Drive, 1914
- [Dr. Thomas C. Peebles House](#), 114 Maple Avenue, ca. 1870

- [George Miller House](#), 331 Central Avenue, ca. 1873
- [Van Horn-Ross House](#), 138 Rosswoods Drive, 1870
- [Tanglewood](#), 417 LaGrange Road, 1869
- [Bondurant-Hustin House](#), 104 Castlewood Drive, 1885
- [Joseph H. Ellis House](#), 320 Maple Avenue, ca. 1890
- [Forrester-Duvall House](#), 115 Old Forest Road, ca. 1908
- ["Sweet Shoppe"](#) 301 LaGrange Road, 1905
- [The Confederate Burying Ground](#), Maple Avenue near Floydsburg Road, est. 1904

Other Extant Historic Sites

- [Telephone Exchange/314 Exchange](#), 1941
- [Caboose](#), placed April 26, 1971
- [Cedarhurst – The Barbee Home](#) (this is outside Pewee Valley and might be a problem), ca. 1800
- [Central Park](#), dedicated September 15, 2015
- [Little Colonel's Cottage](#) – needs title search and we are going to try to get this on the National Register
- [Lockhart-Martin House](#) – needs title search, probably 1850s
- [Pewee Valley First Baptist Church & Colored School](#) (this is outside Pewee Valley and could be a problem), 1867
- [George Metz House](#) – needs title search, ca. 1860
- [Herdt Motors](#), 1910
- [Mail Crane](#), manufactured 1892
- [Norris Summers House](#), 1905
- [Pewee Valley Museum](#), est. 2014
- [Pewee Valley Cemetery East](#), est. 1904 as the official black cemetery, but was part of the original Pewee Valley Cemetery, est. 1871
- [Rollington](#), est. 1830s
- [Schuler House](#), ca. 1850s
- [Sycamore Chapel](#) (this is outside Pewee Valley and could be a problem), 1873
- [Town Hall](#), 1897
- [Wooldridge Hunting Lodge](#), ca. 1905

Other Non-Extant Historic Sites

- [Beechmore/Jennie Casseday Rest Cottage/Mary Crain Private Hospital](#), ca. 1830-1991
- [Clovercroft](#), ca. 1866-1958
- [Interurban](#) (this could be placed with the interurban shelter if we can get it donated and moved), 1902-1935
- [Kentucky College for Young Ladies](#), ca. 1850s-1900
- [Kentucky Confederate Home](#), 1902-1934
- [Martha's Vineyard](#), ca. 1900- (I would have to ask what year it was torn down)
- [McAfee Log Cabin](#) need to do title search
- [James Miller House /Burge Place/Mt. Mercy Camp & Boarding School](#), ca. 1857-1983
- [Old Mill](#) (no longer extant), ca. 1850s
- [Pewee Valley Hospital and Sanitarium](#), 1925-March 15, 1975
- [Pewee Valley Post Office](#), ca. 1890-1990
- [Pewee Valley School](#), 1892-?

- [Railroad Section House](#), ca. 1870-2005
- [Train Depot](#) 1867-1960
- [Undulata](#), ca. 1850-1920 (we could place sign at the old gate to the property on Peace Lane)
- [Villa Ridge Inn](#), 1889-1901 (we could place sign at original main drive next to PV Presbyterian)

Potential Additional Properties

Zaring House (310 Ash Avenue)

Sherman House (116 Rollington Road)

Garrett Foley House (138 Rollington)

130 Rollington Road (created from first St. Al's Church building)

Old Toll House (134 Rollington Road)

Burger House (119 Rest Cottage)

Samuel Curl House (332 Maple)

Blacksmith Shop (no longer extant on Central Avenue)

George Fisher House (Rollington Road at Houston)

Saylor House (6929 LaGrange Road in front of Locust)

Purpose of Signage Program

The City of Pewee Valley has a very unique history, having been the home or summer home of many politicians, wealthy businessmen, writers, artists and other historically important personages over more than a century and a half. That history is also reflected in our unique architectural heritage. At present, the city has 35 properties on the National Register of Historic Places and several others that are eligible for that designation.

The Pewee Valley Historical Society's goal is to preserve that heritage and make it accessible to the public through education and outreach.

In 2014, under Mayor Bob Rogers, the Pewee Valley Museum opened beside Town Hall. The artifact collection has since grown by leaps and bounds. The next year, the Pewee Valley Historian began working in earnest on a website, <http://www.peweevalleyhistory.org/>, to bring that history to life through photos and stories based on extensive historical research. Although the website work is still in progress, it has attracted the attention of professional historians, residents and descendants of families who once lived here. Many have enriched the city's collection of artifacts and photos through donations, additional research and/or providing the PVHS with copies of treasured family photographs.

Oldham County Tourism and the Oldham County Historical Society (OCHS) have long asked that Pewee Valley begin sponsoring regular historical tours. Unfortunately, the PVHS membership is too small to accommodate that request. Although we have sponsored two large events on our Little Colonel connections and the Kentucky Confederate Home, our membership is small. We have a cadre of about eight volunteers who do most of the day-to-day work. Therefore, we needed to develop an alternative to meet the needs of both tourism and the OCHS. The signage program is designed to provide that solution.

The main objective of the Pewee Valley Historical Signage Program is to create a modern, self-guided walking/riding tour that can be promoted by Oldham County Tourism and the OCHS, as well as the City of Pewee Valley. QR codes that can be read by smart phones will take visitors who want to know more about a particular building or location directly to the historical society's webpage about that particular topic.

The codes themselves will be printed as vinyl stickers that can easily be removed and changed should a new and better technology comes along. At present, QR codes are the best and most widely used technology available for this particular application.

Design

Signs will measure 24” by 24” and will be printed flat on both sides (no upraised lettering, etc.) on aluminum using the same type of paint/process as for street signs, with proven longevity in outdoor conditions. They will be categorized and color-themed as follows:

- Historic Homes (42 total)
- Historic Businesses (11 total)
- Historic Churches & Cemeteries (7 total)
- Non-Extant Historic Sites (15 total)

Examples of each type are below. These were designed by PVHS member Shelley Schippert, who works as a professional designer for Brown-Forman:



Two different types of installation will be used, depending on the sign's location. Some locations will require posts. Others will only require a bracket that can be placed on an existing structure. This structure might be a building or in several instances stone gates that mark entrances to non-

extant sites such as the Kentucky College for Young Ladies and Undulata, once the home of poet William D. Gallagher and the Haunted House of Harwell Hollow in the “Little Colonel” stories.

The installation materials we plan to use are shown below:

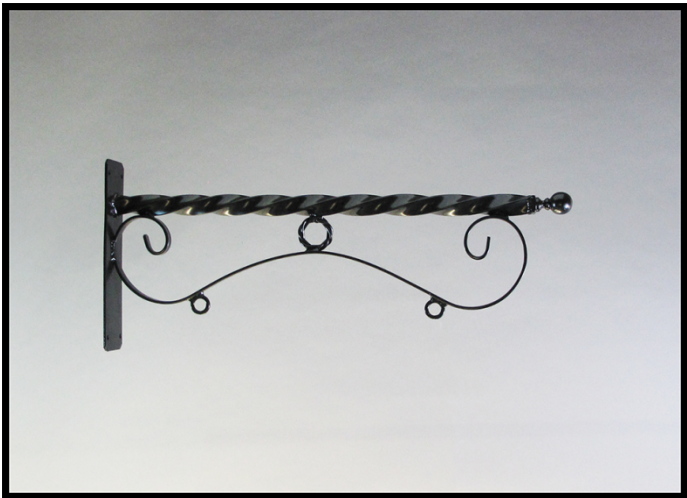

Reverse Scroll Bracket with Ball Finial

X-FN-BAL-RD-2

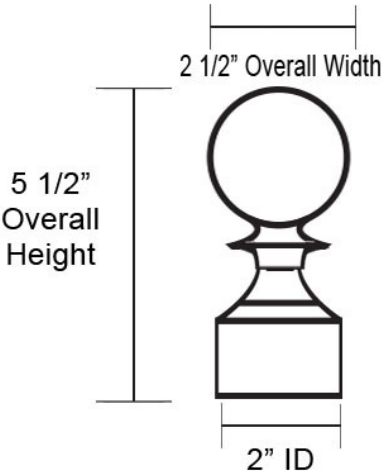

*Measurements may slightly vary.

Ball Finial X-FN-BAL-RD-2 for Post Installations

Round Aluminum 72" Post, 2.5-inch diameter, for Post Installations



Short Decorative Base for Round Poles, 2.5-inch diameter

Signage Program Process

The Historical Signage Program is a long-term project, unless the PVHS can find a single large grant or donor willing to fund the whole thing at one time.

The process we plan to use to make the signage program a reality will consist of the following steps:

STEP ONE	Gain design and overall project approval from the Pewee Valley City Council
STEP TWO	Develop prototype signs for placement on City-owned properties in prominent locations using money left from a grant the PVHS received last January. We can probably afford two signs, one on a post and one attached to a building. Suggested locations include Town Hall/Pewee Valley Museum and the Caboose/Mail Crane. The prototype signs will solve some immediate signage problems for the city, while providing historic property owners with a chance to see what they look like prior to making a decision regarding whether or not they want to participate in the program.
STEP THREE	Once the prototypes are installed, run an article in the “Call of the Pewee” about the program.
STEP FOUR	Contact historic property owners. Those willing to participate will be asked to sign a legal document giving the city permission to place a sign on their property. A decision will also be made regarding the best way to post the sign for maximum visibility: on an existing building, gate or other structure (least expensive) or using a freestanding post (most expensive).
STEP FIVE	Submit the design, number of individual signs required and posting information to vendors for competitive bids.
STEP SIX	Apply for grants at the county, state and federal levels. There are a number of organizations we can approach, including the Gheens Foundation, the Head Trust, Oldham County Tourism, Oldham County Community Fund, Kentucky Historical Society, Museums for America, etc. Out-of-the-gate, we may want to concentrate on signage for our two biggest historic draws: Kentucky Confederate Home sites and Little Colonel sites.
STEP SEVEN	Allow private property owners to purchase signage directly through the program. The PVHS has, from time-to-time, been approached by property owners who want to purchase signage.

CLERK'S OFFICE USE ONLY:

REVISED 2014

DATE RECEIVED _____ \$20 FEE PAID CHK CASH DEP# _____

FOR COUNCIL MEETING DATE: _____

DATE DISTRIBUTED FOR REVIEW: _____

APPROVED AS IS: APPROVED WITH STIPULATIONS: _____